

KWA®

ATP SERIES

(ADAPTIVE TRAINING PISTOL)

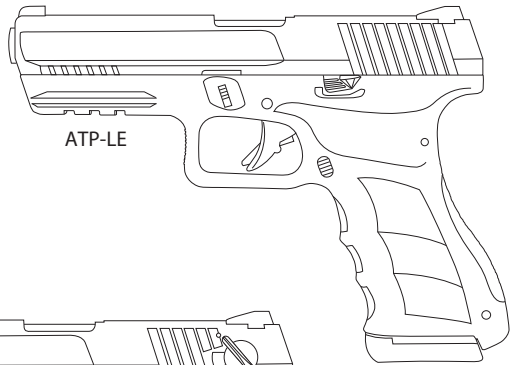

ATP-LE

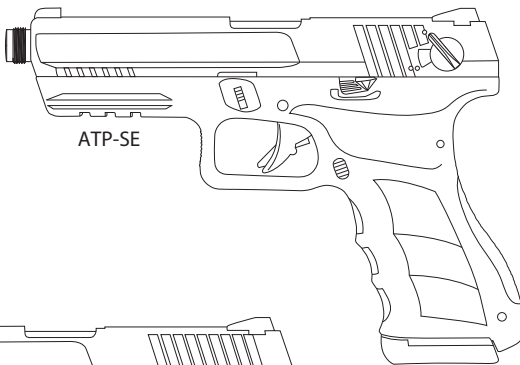

ATP-SE

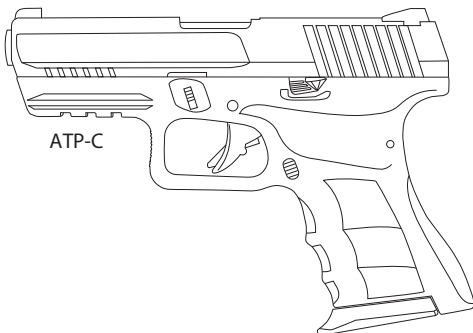

ATP-C

OPERATOR'S MANUAL

Please read this manual carefully before using the Airsoft gun.

TABLE OF CONTENTS

Warranty	3-4
Use of this Manual.....	5
Safety Guidelines.....	5-6
Specifications and Package Contents:	
ATP-LE (Adaptive Training Pistol)	7
ATP-SE (Adaptive Training Pistol).....	8
ATP-C (Adaptive Training Pistol)	9
Charging Gas.....	10
Loading BBs	11
Select Fire (ATP-SE Only)	11
Loading Magazine.....	11
Loading Chamber.....	12
Shooting	12-13
Hop-Up System and Adjustment.....	13-14
Disassembly (ATP-LE and ATP-C).....	15
Disassembly (ATP-SE)	16
Assembly	17
General Maintenance and Cleaning.....	18
Troubleshooting and Operating Under Unusual Conditions	19
Parts Diagram and Parts Lists:	
ATP-LE Parts Diagram	20
ATP-LE Parts List	21
ATP-SE Parts Diagram	22
ATP-SE Parts List.....	23
ATP-C Parts Diagram.....	24
ATP-C Parts List	25
ATP-LE and ATP-SE Magazine Parts Diagram and Parts List.....	26
ATP-C Magazine Parts Diagram and Parts List	27



KWA[®]

WARRANTY

KWA PERFORMANCE INDUSTRIES, INC.

18571 E. Gale Ave.

City of Industry, CA 91748

(626) 581-1777

www.kwausa.com

THANK YOU FOR PURCHASING A KWA PERFORMANCE INDUSTRIES, INC. PRODUCT. KWA Performance Industries, Inc. is committed to serving our customers with the finest quality products, the highest level of service, and the best customer satisfaction. Because of this, we offer a 90 day warranty on all KWA products we import and distribute.

Warranty Coverage

Except as specified below, this warranty covers all defects in material and workmanship in KWA products that occur during the above warranty period. The following are not covered by the warranty: (1) Any product which is not imported and distributed in the U.S.A. by KWA PERFORMANCE INDUSTRIES, INC. (2) Any products not purchased in the U.S.A. from a KWA AUTHORIZED RESELLER. If you are uncertain as to whether a reseller is a KWA AUTHORIZED RESELLER, please contact KWA PERFORMANCE INDUSTRIES, INC. as listed above or visit our website www.kwausa.com (3) Damages, deterioration, or malfunction resulting from: a) An accident, act of nature, abuse, misuse, neglect, opening of or modification or failure to follow instructions supplied with the product. b) Repair or attempted repair by anyone not authorized by KWA PERFORMANCE INDUSTRIES, INC. c) Removal of the orange safety tip. (4) Use of the product outside the U.S.A. (5) Damaged batteries or improper use of bullets (BBs), or non approved propellants (ie. Propane, Red Gas, 134a...etc.) (6) Use in industrial, commercial, and/or professional applications.

What KWA Will Pay For

If your KWA product is found to be defective by KWA Performance Industries, Inc. during the applicable warranty period from the date of original purchase, KWA Performance Industries, Inc. will repair, or at its option, replace with new, used, or equivalent model, the defective product without charge for parts or labor.

How To Obtain Warranty Service

If your product needs service, it may be taken or shipped to KWA Performance Industries, Inc. The following procedures apply whenever your unit must be transported for warranty service:

- You must go to the Help Desk at www.kwausa.com to obtain an RMA number. THE RMA NUMBER MUST BE CLEARLY MARKED ON THE OUTSIDE OF THE PACKAGE. PACKAGES WITHOUT AN RMA NUMBER CLEARLY MARKED WILL BE REFUSED AND RETURNED TO THE SENDER.
- You are responsible for transporting your unit or arranging for its transportation.
- If shipment of your unit is required; you must pay the initial shipping fee, but we will pay the return shipping charge if the repairs are covered by the warranty.
- WHEN RETURNING YOUR UNIT FOR WARRANTY SERVICE, A COPY OF THE ORIGINAL SALES RECEIPT MUST BE ATTACHED.
- You must include the following: RMA number, your name, address, daytime telephone number, model and serial number (if applicable) of the product and a description of the problem.

This Warranty is Only Valid in the United States

If your product does not require service, but you have questions regarding its operation, please contact our Help Desk at www.kwausa.com.

THIS WARRANTY IS EXPRESSLY MADE IN LIEU OF ALL OTHER WARRANTIES, EXPRESSED OR IMPLIED, INCLUDING WITHOUT LIMITATION, WARRANTIES OF MERCHANTABILITY AND FITNESS FOR A PARTICULAR PURPOSE.

OUR LIABILITY IS LIMITED TO THE REPAIR OR REPLACEMENT, AT OUR OPTION, OF ANY DEFECTIVE PRODUCT AND SHALL IN NO EVENT INCLUDE INCIDENTAL OR CONSEQUENTIAL COMMERCIAL OR PROPERTY DAMAGES OF ANY KIND. WE ARE NOT RESPONSIBLE FOR PRODUCTS LOST, STOLEN AND/OR DAMAGED DURING SHIPPING.

SOME STATES DO NOT ALLOW LIMITATIONS ON HOW LONG AN IMPLIED WARRANTY LASTS AND/OR DO NOT ALLOW THE EXCLUSION OF INCIDENTAL OR CONSEQUENTIAL DAMAGES, THE ABOVE LIMITATIONS AND EXCLUSIONS MAY NOT APPLY TO YOU.

This warranty gives you specific legal rights, but you may also have other rights which vary from state to state. This Warranty may not be altered other than in writing signed by an officer of KWA Performance Industries, Inc.

USE OF THIS MANUAL

Before operating your KWA Airsoft Gun, read this manual in its entirety. Important safety topics and tips are discussed throughout all of the chapters. It's important that the operator know the principles of gun handling, safety, and operation prior to firing the Airsoft gun.

SAFETY GUIDELINES

Safety Distance

The effective shooting range is approximately 75 feet. BBs fired from this Airsoft gun may travel farther than intended. Make certain that you have an adequate backstop.

Eye Protection

Eye protection should be worn at all times when shooting and maintaining your Airsoft gun. Protect your eyes from BBs under pressure while performing maintenance on your Airsoft gun.

Assume Every Gun is Always Loaded

Until you are certain the chamber is empty, treat every gun as if it were loaded. Do not assume the chamber is empty.

Beware of Barrel Obstructions

Ensure the Airsoft gun barrel is free of obstructions before you fire the gun. Even the smallest obstruction such as dirt, dust, or a stuck cleaning patch can cause a jam, misfire, or malfunction.

Muzzle Control

Always keep the muzzle of the gun pointed in a safe direction. Never point the muzzle at a person or object that you do not intend to shoot.

Keep Your Safety On

Keep the gun's safety on until your sights are aligned on your target and you are ready to fire.

Keep Your Finger Off The Trigger

Keep your finger off the trigger and out of the trigger guard until your sights are aligned on your target and you are ready to fire.

Identify Your Target and Backstop

Before you pull the trigger, make certain of your target and what is beyond it. The Airsoft gun should never be fired at surfaces such as rocks, glass, water, or other hard surfaces where BBs are likely to ricochet in unpredictable directions.



WARNING:

- Airsoft BBs can be a choking hazard. Keep them away from children.
- Failure to follow safety guidelines may result in serious injury.

SAFETY GUIDELINES (CONTINUED)

Failure To Fire

If the Airsoft gun fails to fire, misfires, or malfunctions, do not look into the gun barrel. BBs can become lodged into the chamber, and serious eye injury may occur.

Maintain Your Gun Properly

Performing proper maintenance, as outlined in this manual, ensures that your Airsoft gun will be safe to shoot and will perform to its designed specifications for many years. Alterations, modifications or adjustments may damage your Airsoft gun, and make it unsafe to shoot.

Store Your Gun Safely

Always store the Airsoft gun in a safe place, and out of reach of children. Always transport the Airsoft gun in a carrying case. Never display the Airsoft gun in a public place. Keep the safety engaged, and remove the magazine before storing the Airsoft gun.

NOTE: IT IS YOUR RESPONSIBILITY TO TAKE EVERY REASONABLE PRECAUTION TO ENSURE THE SAFE STORAGE AND TRANSPORTATION OF YOUR AIRSOFT GUN.

Orange Tip

The orange tip on Airsoft guns helps Law Enforcement distinguish replica guns from their real firearm counterparts. Altering the coloration or markings required by state or Federal law so as to make the product look more like a firearm is dangerous and may be a crime. Operator assumes all risks and responsibility when doing so.

Hazards of Being Mistaken for a Real Firearm

Airsoft guns have been mistaken by Police and Law Enforcement as real firearms. A confrontation with law enforcement while carrying an Airsoft gun can result in serious injury or even death. It is strongly advised to operate the Airsoft gun at a safe and legal location. In the event that you are approached by Law Enforcement personnel, you must comply with their instructions immediately to avoid an incident.

Alcohol, Medications, and Drugs

Do not handle or operate your Airsoft gun while under the influence of alcohol, medication or drugs.

Your Responsibility

Your KWA Airsoft Gun is well-engineered and manufactured to the highest standards. It was carefully inspected before it was packaged and shipped from our factory. Like many other devices, your Airsoft gun is safe unless handled in an irresponsible or uneducated manner.



WARNING:

- Adult supervision is required for any person under the age of 18.
- Alterations and/or modifications to your KWA Airsoft Gun will void all warranty claims.

SPECIFICATIONS: ATP-LE (ADAPTIVE TRAINING PISTOL)

- Overall Length = 197 mm [7.75"]
- Overall Height = 145 mm [5.71"]
- Outer Barrel Length = 119 mm [4.69"]
- Inner Barrel Length = 100 mm
- Inner Barrel Diameter = 6.05 mm
- Weight = 0.70 kg [1.54 lbs]
- Caliber = 6 mm
- Magazine Capacity = 23 rounds
- Velocity = 97-100 MPS [320-330 FPS]
- Energy Output with 0.20g BB = 0.98 Joules
- Gas System = New Structure 2 [NS2]
- Propellant = Green Gas

*Individual test results may vary depending on brand of BBs, ambient temperature, and chronograph used.

Special Features:

- Accessory Rail
- 3-Dot Combat Sights
- Extended Slide Release
- Interchangeable Back Strap
- Front and Rear Slide Serrations
- Adjustable Hop-Up
- Full Metal Alloy Slide
- Polymer Frame
- Gas Operated Recoil Blow Back
- Realistic Construction and Field Stripping

PACKAGE CONTENTS: ATP-LE (ADAPTIVE TRAINING PISTOL)

- 1 ATP-LE Airsoft Gun
- 1 Bottle of Silicone Oil
- 1 Magazine
- 1 Sample Bag of Airsoft BBs
- 1 Hop-Up Adjustment Tool
- 1 Operator's Manual



SPECIFICATIONS: ATP-SE (ADAPTIVE TRAINING PISTOL)

- Overall Length = 203.2 mm [8"]
- Overall Height = 145 mm [5.71"]
- Outer Barrel Length = 123.83 mm [4.88"]
- Inner Barrel Length = 100 mm
- Inner Barrel Diameter = 6.05 mm
- Weight = 0.70 kg [1.54 lbs]
- Caliber = 6 mm
- Magazine Capacity = 23 rounds
- Velocity = 97-100 MPS [320-330 FPS]
- Energy Output with 0.20g BB = 0.98 Joules
- Gas System = New Structure 2 [NS2]
- Propellant = Green Gas

*Individual test results may vary depending on brand of BBs, ambient temperature, and chronograph used.

Special Features:

- Accessory Rail
- 3-Dot Combat Sights
- Extended Slide Release
- Interchangeable Back Strap
- Front and Rear Slide Serrations
- Semi and Full Auto Select Fire
- Adjustable Hop-Up
- Full Metal Alloy Slide
- Polymer Frame
- Gas Operated Recoil Blow Back
- Realistic Construction and Field Stripping

PACKAGE CONTENTS: ATP-SE (ADAPTIVE TRAINING PISTOL)

- 1 ATP-SE Airsoft Gun
- 1 Bottle of Silicone Oil
- 1 Magazine
- 1 Sample Bag of Airsoft BBs
- 1 Hop-Up Adjustment Tool
- 1 Operator's Manual

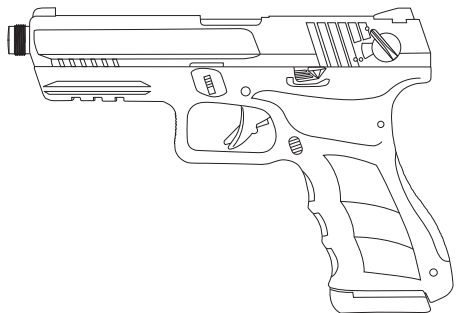

SPECIFICATIONS: ATP-COMPACT (ADAPTIVE TRAINING PISTOL)

- Overall Length = 177.8 mm [7"]
- Overall Height = 127 mm [5"]
- Outer Barrel Length = 101.5 mm [3.996"]
- Inner Barrel Length = 88.5 mm
- Inner Barrel Diameter = 6.05 mm
- Weight = 0.675 kg [1.488 lbs]
- Caliber = 6 mm
- Magazine Capacity = 19 rounds
- Velocity = 97-100 MPS [320-330 FPS]
- Energy Output with 0.20g BB = 0.98 Joules
- Gas System = New Structure 2 [NS2]
- Propellant = Green Gas

*Individual test results may vary depending on brand of BBs, ambient temperature, and chronograph used.

Special Features:

- Accessory Rail
- 3-Dot Combat Sights
- Extended Slide Release
- Front and Rear Slide Serrations
- Adjustable Hop-Up
- Full Metal Alloy Slide
- Polymer Frame
- Gas Operated Recoil Blow Back
- Realistic Construction and Field Stripping

PACKAGE CONTENTS: ATP-COMPACT (ADAPTIVE TRAINING PISTOL)

- 1 ATP-COMPACT Airsoft
- Gun 1 Bottle of Silicone Oil
- 1 Magazine
- 1 Sample Bag of Airsoft BBs
- 1 Hop-Up Adjustment Tool
- 1 Operator's Manual

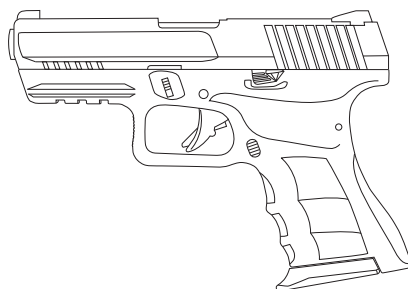

CHARGING GAS

1. Release the magazine by pressing the magazine catch button.
2. Hold the magazine upside down. Release the base plate lock, then gently push the base plate forward to reveal the charging valve.
3. Push the gas canister nozzle into the charging valve. (Make sure both the canister and magazine are inverted and in the vertical position when charging.)
4. Charge the magazine until gas overflows from the charging valve. (approximately 20 seconds.)

Note: It is normal to have minor leaking from the charging valve during charging due to high pressure built up inside the magazine. It is recommended to keep the gas release valve slightly oiled. Room temperature is the ideal temperature for shooting. You may experience a delayed action if the surrounding temperature drops below 68° F.

Note: Do not expose the magazine to direct sunlight or incinerate the magazine, as this may cause the magazine to burst. It is strongly recommended to empty the gas from the magazine after shooting. Be certain that the gas does not make contact with eyes or skin while being released, as any contact will cause cold burns.

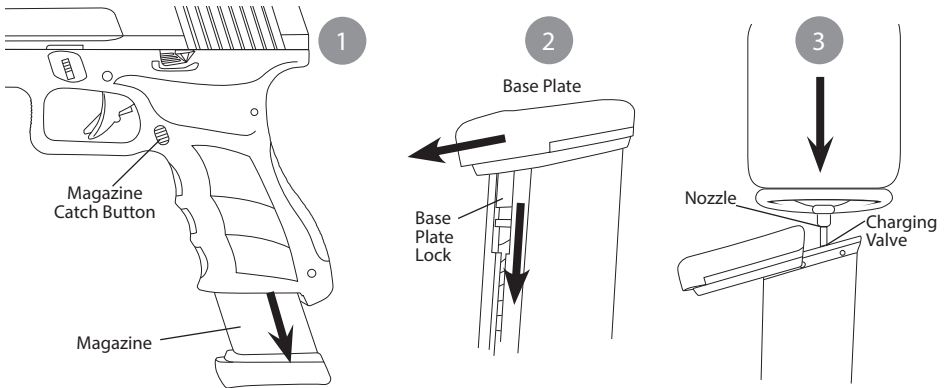

Green Gas safety tips:

- Check the canister for any cracks or leaks before using.
- Do not expose the canister to temperature over 104° F.
- Do not leave the canister directly over fire.
- Do not heat the canister.
- Keep the canister away from direct sunlight.
- Do not leave the canister in any type of vehicle.



WARNING:

- Avoid dropping the magazine. Sudden impact with a hard surface may cause damage to the magazine.

LOADING BBs

1. Pull the magazine follower down until it locks.
2. Insert BBs into the magazine lip.
3. Make sure to have a 3mm clearance between BBs and the top lip of the magazine.
4. Push the magazine follower lock to release.

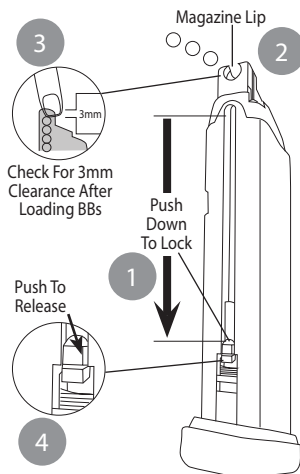

SELECT FIRE (ATP-SE ONLY)

Note: The slide must be in the rear-most position prior to changing the select fire mode.

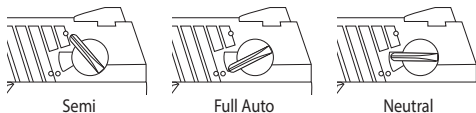
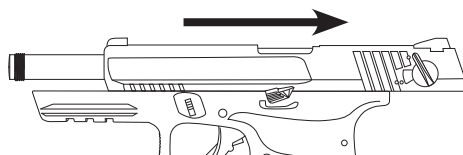

LOADING MAGAZINE

1. Place the magazine back into the magazine well.
2. Push the magazine up until it clicks into a locked position.
3. Pull on the magazine to assure that it is locked in place.

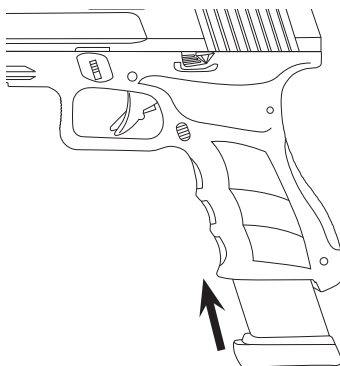

WARNING:

- Do not release the magazine follower when the magazine is not completely filled with BB's. Doing so will damage the magazine and magazine follower.

LOADING CHAMBER

Pull the slide to the rear-most position and release the slide. This will automatically load the first BB into the chamber. The hammer will be in a cocked position. Make sure not to skip this procedure. Skipping this step will cause a misfire on the first pull of the trigger. The slide will lock open when the last BB is fired.

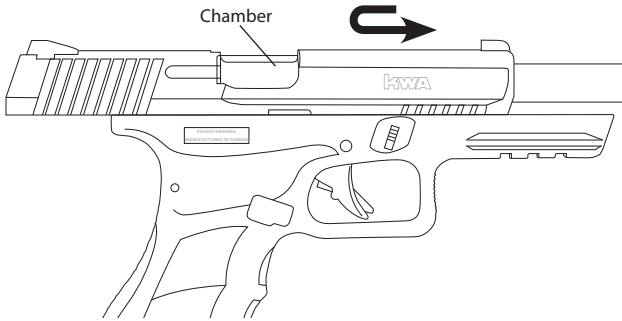

SHOOTING

1. Make sure the gun is cocked.
2. Grasp the Airsoft gun in your hand firmly. A two-hand hold with one hand wrapped around the other will help control the Airsoft gun.
3. Release the safety and squeeze the trigger. The blow back action will load the remaining BBs automatically as the slide cycles back and forth.
4. The slide will lock back in the open position when the last BB is fired.

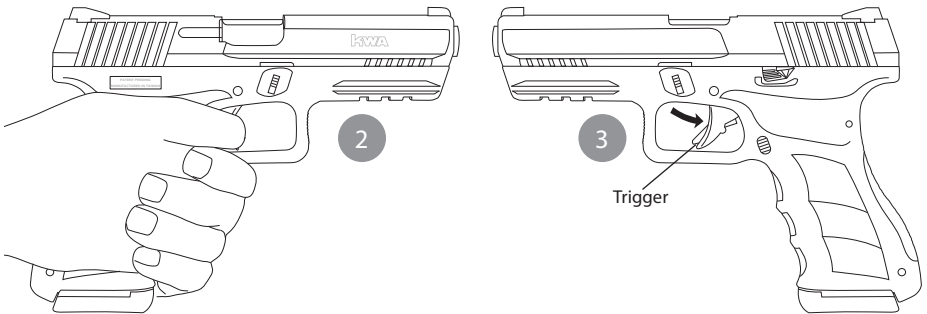

WARNING:

- Never shoot the gun in a horizontal or upside-down position.
- Do not fire the pistol without a magazine inserted. Doing so may damage the impact block and result in the loss of the impact pin.
- Always use high quality 6mm BBs, weighing 0.2g or heavier. Using recycled or low grade BBs will damage your gun.

SHOOTING (CONTINUED)

OPEN SLIDE

The slide will remain open after the last BB has been fired. Remove the empty magazine and replace it with a loaded magazine before releasing the slide catch lever. The first BB will be automatically loaded into the chamber.

Note: It is important to treat your gun as if it were loaded even when the slide is open.

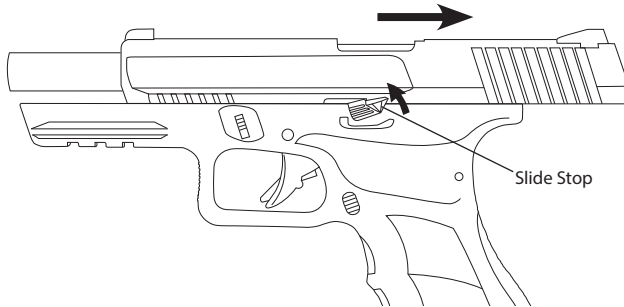

AFTER SHOOTING

After you are finished shooting, remove the magazine and visually examine the open chamber to check for clearance. Make sure both the magazine and the chamber are clear, then release the slide.

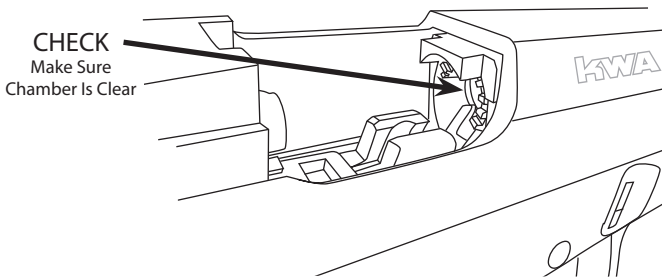

HOP-UP SYSTEM

The Hop-Up device is one of KWA's standard features, giving Airsoft BBs greater stability, farther travel and increased accuracy. Airsoft BBs are light-weight and can be affected by wind when fired. With the Hop-Up system, the trajectory of the Airsoft BBs can be adjusted according to the shooting environment or surroundings.

HOP-UP SYSTEM (CONTINUED)







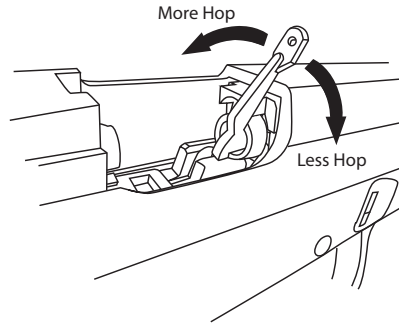
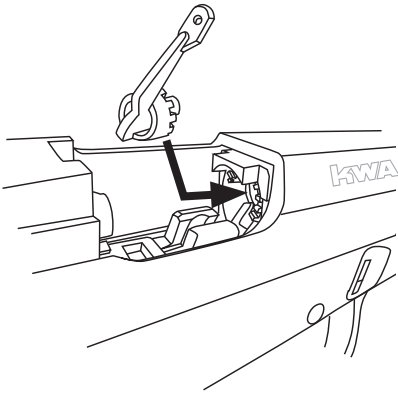



HOP-UP ADJUSTMENT

To adjust the Hop-Up, make sure the magazine is loaded and that you have at least 65 feet of clearance for a test fire before making any adjustments.

1. Test fire the gun for 10 to 20 rounds and observe the BB's traveling pattern.
2. Remove the magazine.
3. Open the slide and place adjusting tool into the slotted chamber ring. Turn the adjusting ring a 1/4-inch at a time.
4. If the BBs are dropping too quickly, move the adjusting ring to the left or counter-clockwise to give the BB more hop. If the BBs are dropping too slowly, move the adjusting ring to the right or clock-wise.
5. Test fire and adjust as needed.



HOP-UP ADJUSTMENT POINT

BB TRAJECTORY PATTERN		ADJUSTMENTS
	BB DROPS FREELY	 TURN KNOB TO RIGHT
	BB TRAVELS AT SHORT TRAJECTORY PATH	 TURN KNOB SLIGHTLY TO RIGHT
	BB TRAVELS DISTANCE AT FLAT TRAJECTORY PATH	 NO ADJUSTMENT MADE
	BB TRAVELS FLAT IN SHORT DISTANCE, THEN GOES UP IN CURVE AND DROPS FREELY	 TURN KNOB SLIGHTLY TO LEFT
	BB TRAVELS AT UNSTABLE SPEED AND IRREGULAR PATH	 TURN KNOB TO LEFT

DISASSEMBLY (ATP-LE and ATP-COMPACT)

It is not recommended to disassemble the gun unless for general maintenance, or to clear BBs jammed inside the barrel.

1. Remove the magazine by depressing the magazine catch button on the left side of the Airsoft gun. Check and clear the chamber of BBs.
2. Push the take-down lever downward from both sides of the frame.
3. While the take-down lever is lowered, pull slide backward to release the slide stop then push the slide forward and away from the frame.
4. Remove the guide rod and recoil spring assembly.
5. Slide the barrel out from underneath the slide.

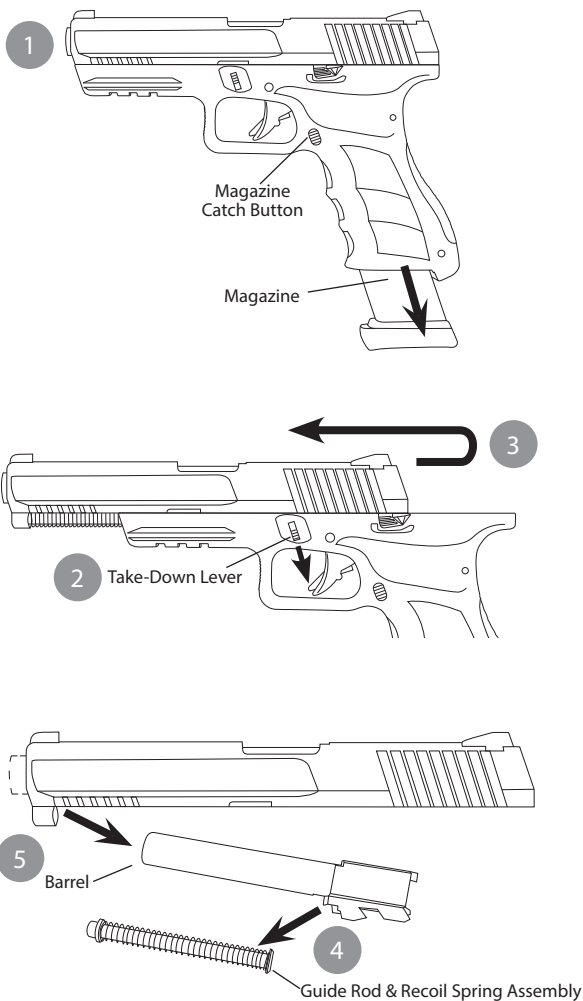

DISASSEMBLY (ATP-SE)

It is not recommended to disassemble the gun unless for general maintenance, or to clear BBs jammed inside the barrel.

1. Remove the magazine by depressing the magazine catch button on the left side of the Airsoft gun. Check and clear the chamber of BBs.
2. Move the slide to the rear most position and lock in place with the slide stop.
3. Turn the selector switch to the neutral position.
4. Push the take-down lever downward from both sides of the frame.
5. While the take-down lever is lowered, pull slide backward to release the slide stop then push the slide forward and away from the frame.
6. Remove the guide rod and recoil spring assembly.
7. Slide the barrel out from underneath the slide.

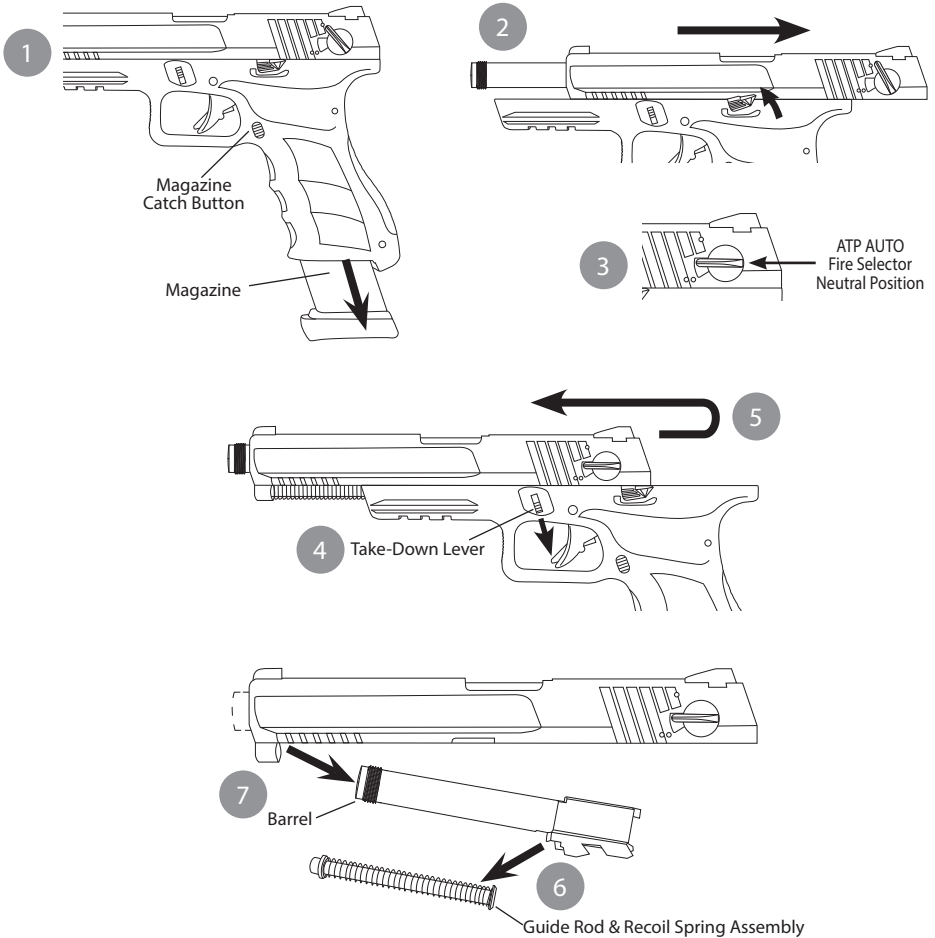

ASSEMBLY

1. Make sure the hammer is in the down position.
2. Place the barrel into the slide.
3. Install the guide rod and recoil spring assembly into position.
4. Apply pressure on the guide rod and recoil spring assembly. Put the assembled slide onto the frame rails and glide it toward the rear of the gun.
5. Pull the slide to rear most position and then release.

NOTE: After assembly is completed, cycle the slide back and forth to insure proper assembly.

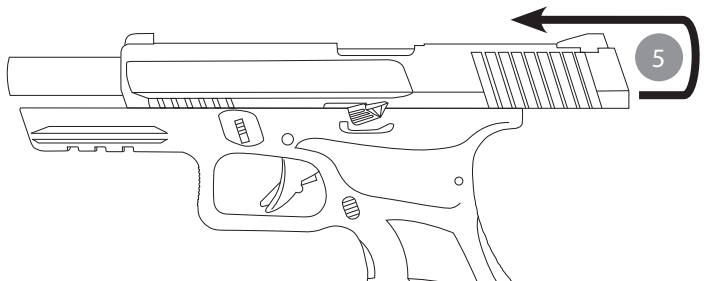
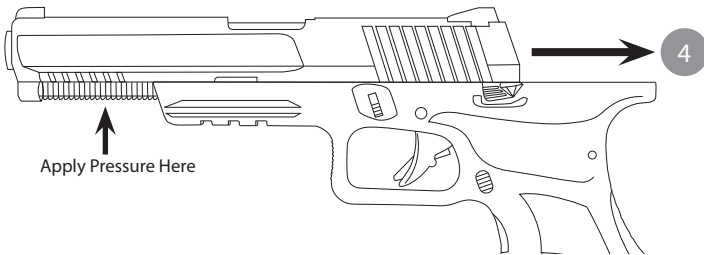
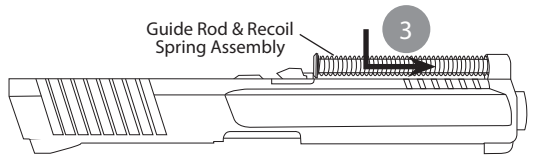
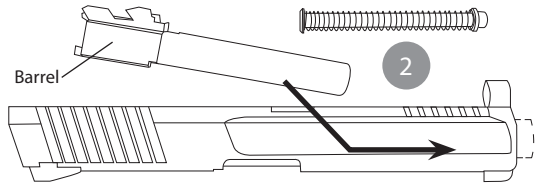
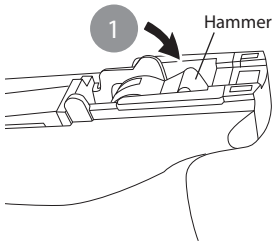

GENERAL MAINTENANCE FOR KWA GAS BLOW BACK

Green gas is a liquid propellant which tends to dry out the seals and o-rings. With lubricating silicone oil, it will extend the life of the seals and o-rings and prevent gas leaks.

Use only the recommended 100% silicone oil, available for purchase at the Airsoft dealer where you purchased your KWA products. Any other type of lubricant may damage the products.

Lightly lubricate the recoil spring, cylinder and moving parts with a few drops of oil. Lubricating the seals and o-rings are essential. Unload BBs from the magazine. Make sure the magazine is free of gas before lubricating the magazine's charging valve and release valve.

CLEANING

The Airsoft gun inner barrel should be cleaned after each shooting session. Regular cleaning prevents damage that can be caused by excess oil, dirt, BB residue, and debris buildup.

Cleaning Procedure

1. Ensure that the safety is engaged.
2. Remove the magazine and clear the chamber of loaded BBs.
3. Disable Hop-Up by dialing to the OFF Position (see Hop-Up Section on page 12).
4. Disassemble the receiver (see Disassembly section on page 13).
5. Steps to use cleaning rod:
 - a. Cut a piece of clean cotton cloth to 1 inch by 0.5 inch size. Insert one end of the cloth into the hole in the cleaning rod (adjust the length of cloth for smooth entry into the barrel).
 - b. Wind the cloth around the cleaning rod.
 - c. Insert the cleaning rod into the inner barrel, and push the rod through.
 - d. Remove the cleaning rod and check the cotton cloth for dirt. Repeat steps 5a-5c when necessary.

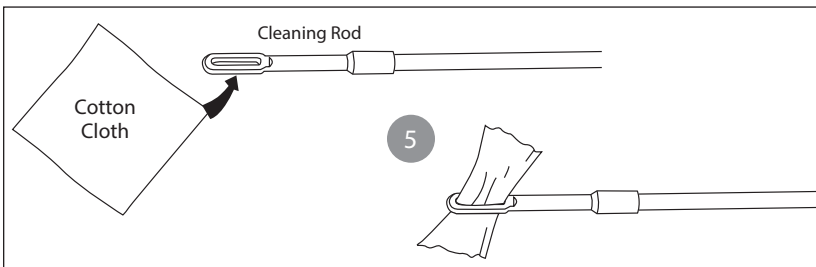

WARNING:

- Unload and clear the Airsoft gun before cleaning.
- DO NOT use spray silicone oil as a cleaning solution for the inner barrel.

BASIC TROUBLESHOOTING GUIDE FOR PISTOL

SYMPTOMS	POSSIBLE CAUSE	SOLUTIONS
Slide jams / Will not complete cycle	Dry internals	Add silicone to cylinder / main seal
Double feeds BBs into Chamber / BB's roll out of barrel	Hop-up adjustment too tight	Release hop-up or replace bucking
BBs will not release from magazine / bent mag lip/ check BB condition	Bent magazine lip	Replace magazine lip
Leaking release valve & charging valve	Dry O-ring	Add silicone oil to valves / Replace valves
Slide stop engages while shooting BBs	Weak slide stop spring	Adjust tension
Magazine base plate will not lock	Broken base plate lock	Replace base plate lock
Magazine base leaking air	Worn out base seal	Replace magazine base seal
Cylinder will not load BBs into chamber	Broken cylinder tab	Replace cylinder
Trigger will not reset	Worn out trigger spring / trigger bow spring	Replace trigger spring / trigger bow spring

OPERATING UNDER UNUSUAL CONDITIONS

Unusual conditions are defined as any condition requiring special maintenance. Perform maintenance outlined for the climate similar to your operational area.

Extreme Cold:

Operating an Airsoft gas gun in extremely cold temperatures is not recommended. Cold temperatures will cause the Hop-up Bucking to harden, reducing its effectiveness. Gas will not expand properly in cold temperatures, so both the cycling rate and power will be dramatically reduced.

Extreme Heat:

Operating an Airsoft gas gun in extremely hot temperatures is also not recommended. Leaving the gun in direct sunlight for long periods of time, or operating in extremely hot areas will cause the gas to over-expand, damaging the internal workings of the gun. The increase in internal pressure from the expanding gas can also damage the seals and cause leaks in the magazine.

Dust or Sand:

Dust or sand can get into a gas gun and cause malfunctions and/or excessive wear. Keep the gun covered whenever possible. Use lubricant sparingly, as lube naturally attracts dirt and other particles. After use in a dusty area, always field strip the gun (refer to Disassembly Section) and clean any areas you can reach with a soft, lint-free cloth.

ATP-LE PARTS DIAGRAM

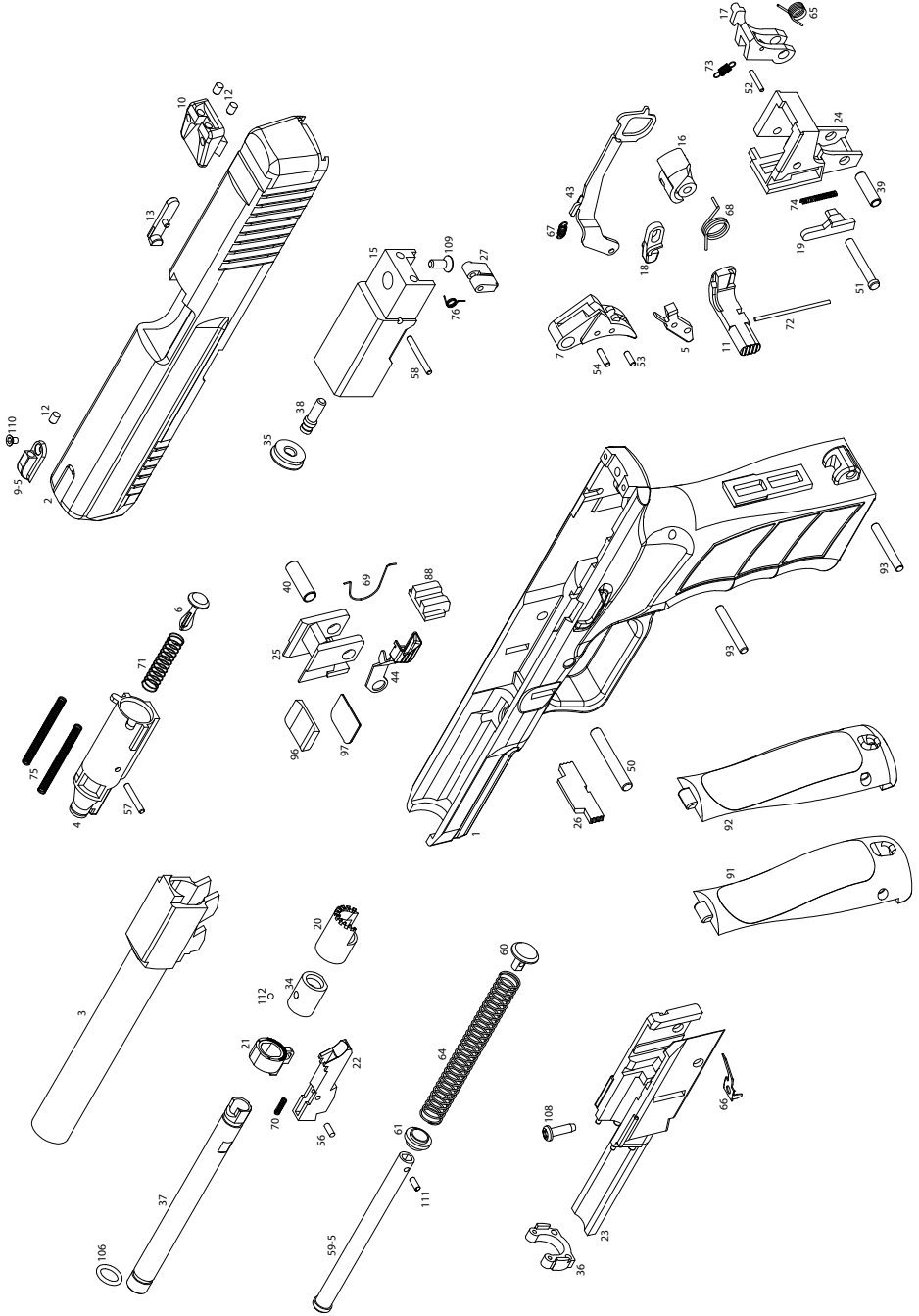

ATP-LE PARTS LIST

Part #	Description
199-0102-1	Frame
199-0102-2	Slide
199-0102-3	Outer Barrel
199-0102-4	Cylinder
199-0102-5	Trigger Safety
199-0102-6	Jet Nozzle
199-0102-7	Trigger
199-0102-9-5	Front Sight
199-0102-10	Rear Sight
199-0102-11	Magazine Catch
199-0102-12	Sight Insert x3
199-0102-13	Extractor
199-0102-15	Breech
199-0102-16	Hammer
199-0102-17	Sear
199-0102-18	Impact Block
199-0102-19	Impact Block Reset Bar
199-0102-20	Hop-Up Cylinder
199-0102-21	Inner Barrel Base
199-0102-22	Feed Ramp
199-0102-23	Inner Frame
199-0102-24	Hammer Block
199-0102-25	Trigger Housing
199-0102-26	Take-Down Lever
199-0102-27	Hammer Reset Block
199-0102-34	Hop-Up Bucking
199-0102-35	Main Seal
199-0102-36	Recoil Buffer
199-0102-37	Inner Barrel
199-0102-38	Breech Pin
199-0102-39	Sear Sleeve
199-0102-40	Trigger Block Sleeve
199-0102-43	Trigger Transfer Bar
199-0102-44	Slide Stop Lever
199-0102-50	Trigger Block Pin

Part #	Description
199-0102-51	Hammer Pin
199-0102-52	Sear Pin
199-0102-53	Trigger Safety Pin
199-0102-54	Trigger Transfer Bar Pin
199-0102-56	Feed Ramp Pin
199-0102-57	Jet Nozzle Pin
199-0102-58	Reset Block Pin
199-0102-59-5	Guide Rod
199-0102-60	Guide Rod End Cap
199-0102-61	Recoil Spring Retainer
199-0102-64	Recoil Spring
199-0102-65	Sear Spring
199-0102-66	Take-Down Lever Spring
199-0102-67	Trigger Bar Spring
199-0102-68	Hammer Spring
199-0102-69	Slide Stop Lever Spring
199-0102-70	Feed Ramp Spring
199-0102-71	Jet Valve Spring
199-0102-72	Magazine Catch Spring
199-0102-73	Impact Block Spring
199-0102-74	Impact Reset Bar Spring
199-0102-75	Cylinder Return Springs x2
199-0102-76	Hammer Reset Block Spring
199-0102-88	Magwell Alignment Block
199-0102-91	Back Strap / Large
199-0102-92	Back Strap / Small
199-0102-93	Frame Pins x2
199-0102-96	Serial Number Plate Cover
199-0102-97	Serial Number Plate
199-0102-106	Inner Barrel O-Ring
199-0102-108	Inner Frame Screw
199-0102-109	Breech Screw
199-0102-110	Front Sight Screw
199-0102-111	Guide Rod Pin
199-0102-112	Hop-Up Ball Bearing

ATP-SE PARTS DIAGRAM

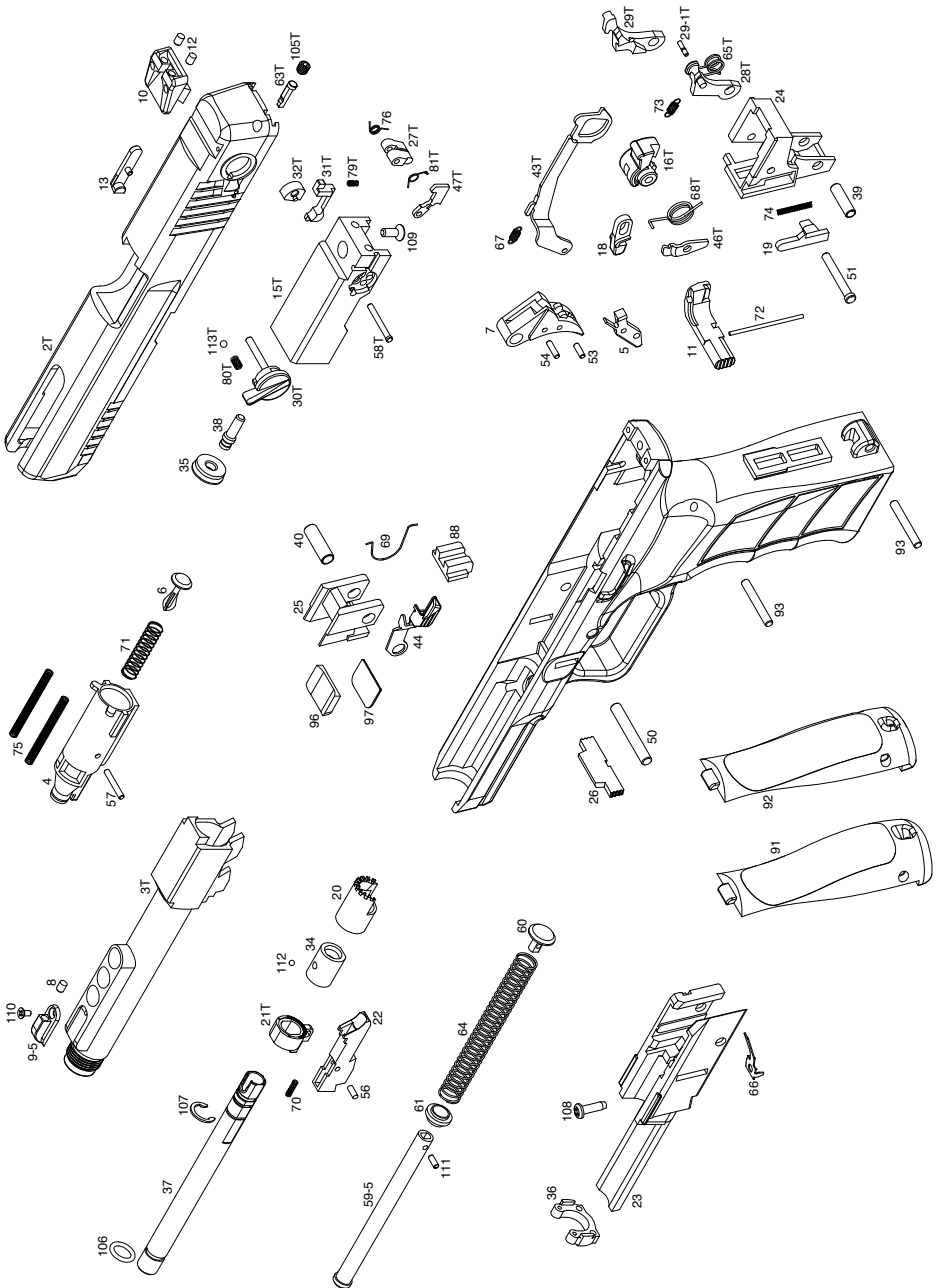

ATP-SE PARTS LIST

Part #	Description
199-0102-1	Frame
199-0102-2T	Slide
199-0102-3T	Outer Barrel
199-0102-4	Cylinder
199-0102-5	Trigger Safety
199-0102-6	Jet Nozzle
199-0102-7	Trigger
199-0102-8	Front Sight Insert
199-0102-9-5	Front Sight
199-0102-10	Rear Sight
199-0102-11	Magazine Catch
199-0102-12	Rear Sight Insert x2
199-0102-13	Extractor
199-0102-15T	Breech
199-0102-16T	Hammer
199-0102-18	Impact Block
199-0102-19	Impact Block Reset Bar
199-0102-20	Hop-Up Cylinder
199-0102-21T	Hop-Up Cylinder Clamp
199-0102-22	Feed Ramp
199-0102-23	Inner Frame
199-0102-24	Hammer Block
199-0102-25	Trigger Block
199-0102-26	Take-Down Lever
199-0102-27T	Hammer Reset Block
199-0102-28T	Left Sear
199-0102-29T	Right Sear
199-0102-29-1T	Sear Pin
199-0102-30T	Selector Lever
199-0102-31T	Selector Cam Bar
199-0102-32T	Selector Cam
199-0102-34	Hop-Up Bucking
199-0102-35	Main Seal
199-0102-36	Recoil Buffer
199-0102-37	Inner Barrel
199-0102-38	Breech Pin
199-0102-39	Sear Sleeve
199-0102-40	Trigger Block Sleeve
199-0102-43T	Trigger Transfer Bar
199-0102-44	Slide Stop Lever
199-0102-46T	Left Sear Disconnecter
199-0102-47T	Selector Lever Hook

Part #	Description
199-0102-50	Trigger Block Pin
199-0102-51	Hammer Pin
199-0102-53	Trigger Safety Pin
199-0102-54	Trigger Transfer Bar Pin
199-0102-56	Feed Ramp Pin
199-0102-57	Jet Nozzle Pin
199-0102-58T	Hammer Reset Block Pin
199-0102-59-5	Recoil Spring Guide Rod
199-0102-60	Recoil Spring Guide Cap
199-0102-61	Recoil Spring Guide Bushing
199-0102-63T	Selector Pin
199-0102-64	Recoil Spring
199-0102-65T	Sear Spring
199-0102-66	Take-Down Lever Spring
199-0102-67	Trigger Reset Spring
199-0102-68T	Hammer Spring
199-0102-69	Slide Stop Spring
199-0102-70	Inner Barrel Spring
199-0102-71	Jet Nozzle Spring
199-0102-72	Magazine Catch Spring
199-0102-73	Impact Block Return Spring
199-0102-74	Impact Block Reset Spring
199-0102-75	Cylinder Return Springs x2
199-0102-76	Hammer Reset Spring
199-0102-79T	Selector Cam Bar Spring
199-0102-80T	Selector Lever Spring
199-0102-81T	Selector Lever Hook Spring
199-0102-88	Magwell Alignment Block
199-0102-91	Back Strap (Wide)
199-0102-92	Back Strap (Slim)
199-0102-93	Back Strap Pin x2
199-0102-96	Serial Number Plate Stop
199-0102-97	Serial Number Plate
199-0102-105T	Selector Pin Screw
199-0102-106	Inner Barrel O-Ring
199-0102-107	Inner Barrel C-Clamp
199-0102-108	Inner Base Frame Screw
199-0102-109	Breech Screw
199-0102-110	Lock Screws x4
199-0102-111	Recoil Spring Guide Pin
199-0102-112	Hop-Up Ball
199-0102-113T	Selector Lever Detent Ball

ATP-COMPACT PARTS DIAGRAM

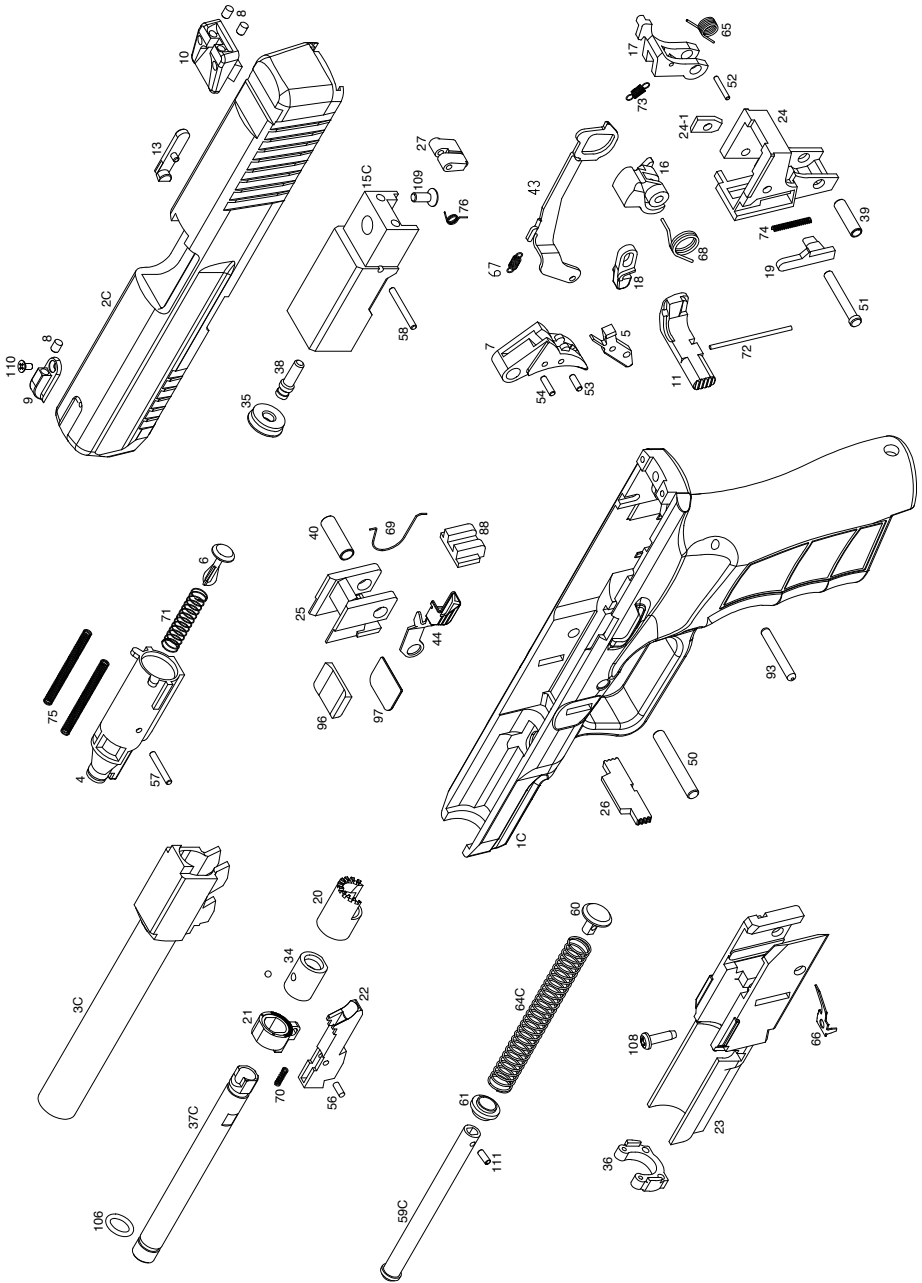

ATP-COMPACT PARTS LIST

Part #	Description
199-0102-1C	Frame
199-0102-2C	Slide
199-0102-3C	Outer Barrel
199-0102-4	Cylinder
199-0102-5	Trigger Safety
199-0102-6	Jet Nozzle
199-0102-7	Trigger
199-0102-8	Sight Inserts x3
199-0102-9	Front Sight
199-0102-10	Rear Sight
199-0102-11	Magazine Catch
199-0102-13	Extractor
199-0102-15C	Breech
199-0102-16	Hammer
199-0102-17	Sear
199-0102-18	Impact Block
199-0102-19	Impact Block Reset
199-0102-20	Hop-Up Adjustment Hood
199-0102-21	Inner Barrel Sleeve
199-0102-22	Feed Ramp
199-0102-23	Inner Frame
199-0102-24	Hammer Block
199-0102-24-1	Hammer Block Spacer
199-0102-25	Trigger Block
199-0102-26	Take-Down Lever
199-0102-27	Hammer Reset Block
199-0102-34	Hop-Up Bucking
199-0102-35	Main Seal
199-0102-36	Recoil Buffer
199-0102-37C	Inner Barrel
199-0102-38	Breech Pin
199-0102-39	Sear Sleeve
199-0102-40	Trigger Block Sleeve
199-0102-43	Trigger Transfer Bar
199-0102-44	Slide Stop Lever

Part #	Description
199-0102-50	Trigger Block Pin
199-0102-51	Hammer Pin
199-0102-52	Sear Pin
199-0102-53	Trigger Safety Pin
199-0102-54	Trigger Transfer Bar Pin
199-0102-56	Feed Ramp Pin
199-0102-57	Jet Nozzle Pin
199-0102-58	Hammer Reset Block Pin
199-0102-59C	Recoil Spring Guide Rod
199-0102-60	Recoil Spring Guide Cap
199-0102-61	Recoil Spring Guide Bushing
199-0102-64C	Recoil Spring
199-0102-65	Sear Spring
199-0102-66	Take-Down Lever Spring
199-0102-67	Trigger Reset Spring
199-0102-68	Hammer Spring
199-0102-69	Slide Stop Spring
199-0102-70	Inner Barrel Spring
199-0102-71	Jet Nozzle Spring
199-0102-72	Magazine Catch Spring
199-0102-73	Impact Block Return Spring
199-0102-74	Impact Block Reset Spring
199-0102-75	Cylinder Return Springs x2
199-0102-76	Hammer Reset Spring
199-0102-88	Magwell Alignment Block
199-0102-93	Hammer Housing Pin
199-0102-96	Serial Number Plate Cover
199-0102-97	Serial Number Plate
199-0102-106	Inner Barrel O-Ring
199-0102-108	Inner Frame Screw
199-0102-109	Breech Screw
199-0102-110	Front Sight Screw
199-0102-111	Recoil Spring Cap Pin
199-0102-112	Hop-Up Ball Bearing

ATP-LE/ATP-SE MAGAZINE PARTS DIAGRAM & PARTS LIST

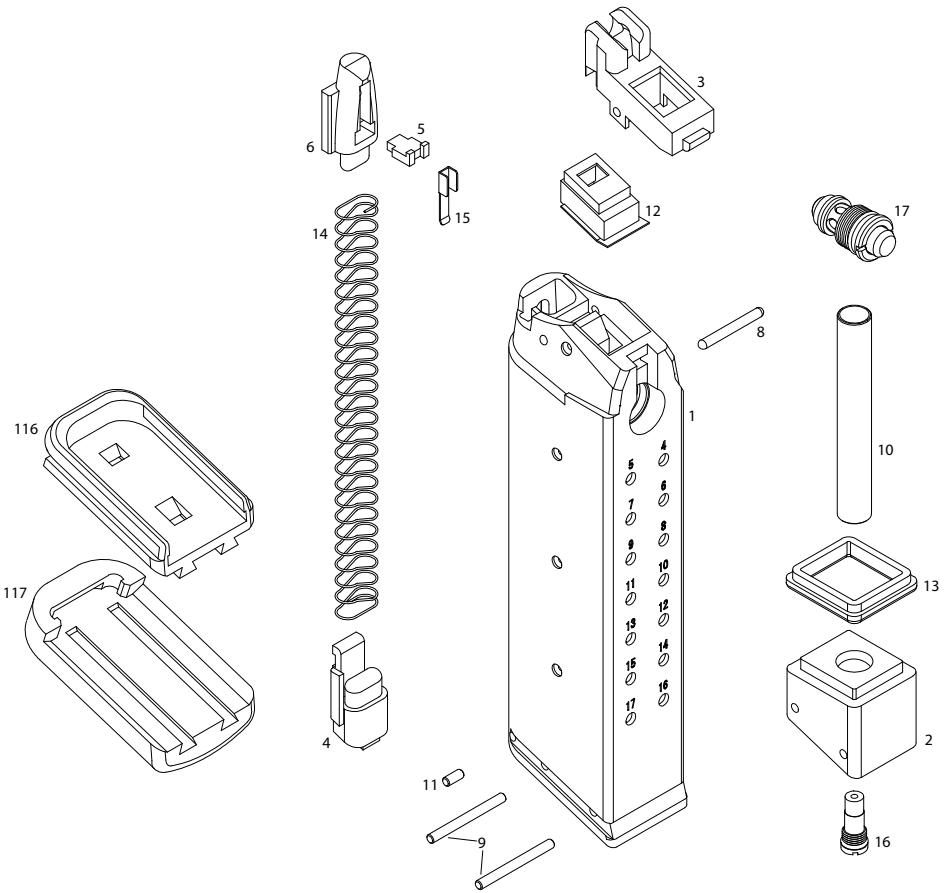

Part #	Description
199-0102-MG1	Magazine Body
199-0102-MG2	Base
199-0102-MG3	Feed Lip
199-0102-MG4	Base Plate Lock
199-0102-MG5	Follower Lock
199-0102-MG6	Follower
199-0102-MG8	Feed Lip Pin
199-0102-MG9	Base Pins x2
199-0102-MG10	Expansion Tube

Part #	Description
199-0102-MG11	Base Plate Lock Pin
199-0102-MG12	Nozzle Seal
199-0102-MG13	Rubber Base Seal
199-0102-MG14	Follower Spring
199-0102-MG15	Follower Lock Spring
199-0102-MG16	Charge Valve
199-0102-MG17	Release Valve
199-0102-MG116	Base Plate
199-0102-MG117	Base Plate Bumper

ATP-COMPACT MAGAZINE PARTS DIAGRAM & PARTS LIST

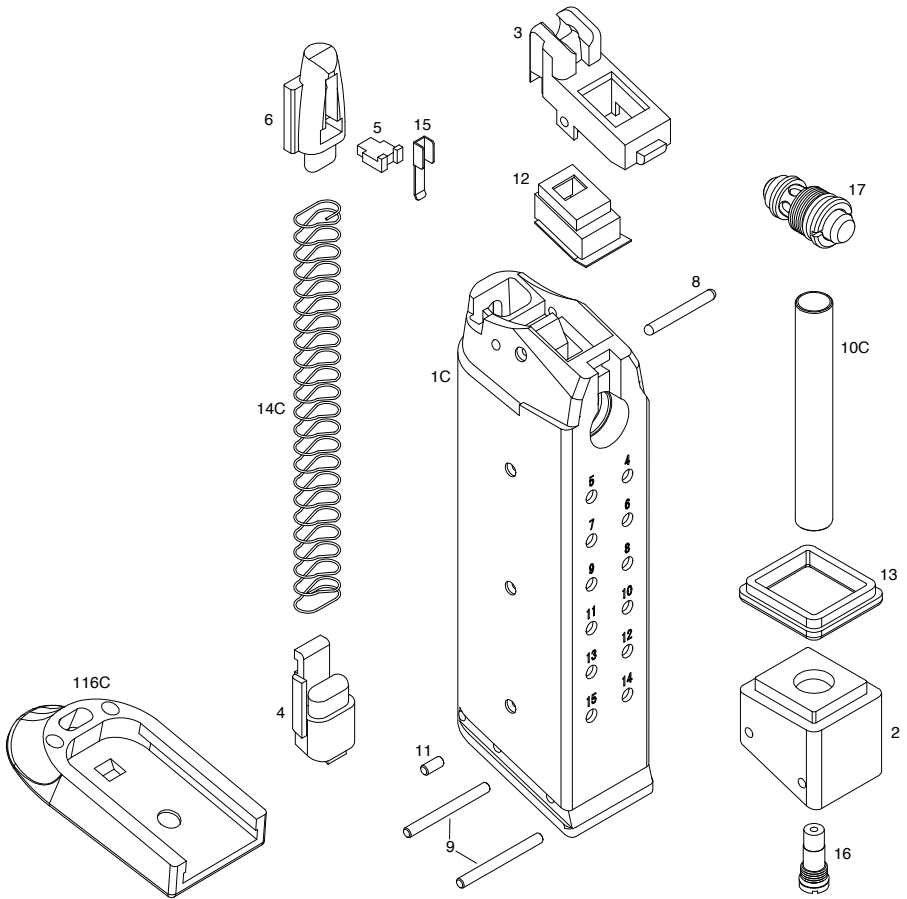

Part #	Description
199-0102-MG1C	Magazine Body
199-0102-MG2	Base
199-0102-MG3	Feed Lip
199-0102-MG4	Base Plate Lock
199-0102-MG5	Follower Lock
199-0102-MG6	Follower
199-0102-MG8	Feed Lip Pin
199-0102-MG9	Base Pins x2
199-0102-MG10C	Expansion Tube

Part #	Description
199-0102-MG11	Base Plate Lock Pin
199-0102-MG12	Nozzle Seal
199-0102-MG13	Rubber Base Seal
199-0102-MG14C	Follower Spring
199-0102-MG15	Follower Lock Spring
199-0102-MG16	Charge Valve
199-0102-MG17	Release Valve
199-0102-MG116C	Base Plate



KWA Performance Industries, Inc.

18571 E. Gale Ave.

City of Industry, CA 91748

T: (626) 581-1777 • F: (626) 581-0777

WWW.KWAUSA.COM